

RESCUE BOAT RIBO 450 P SLING

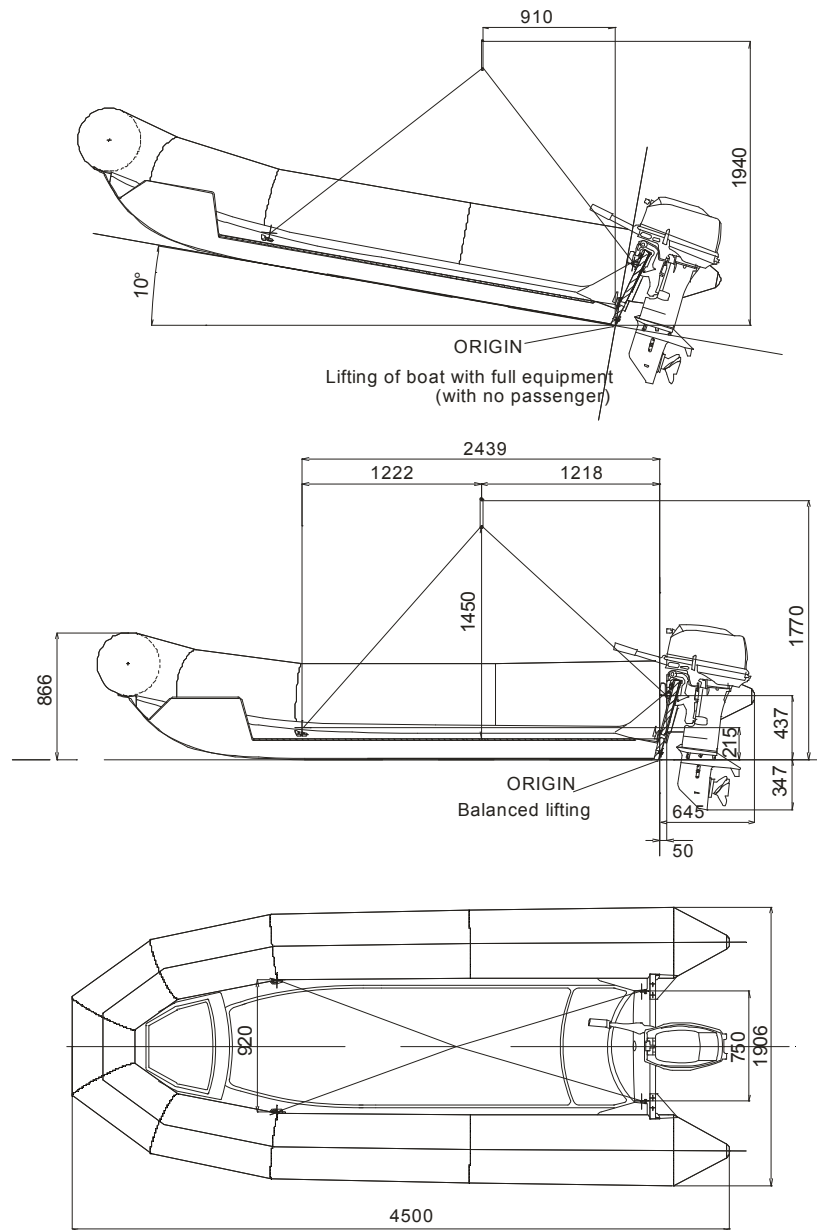

Bowsing line length = 1835 mm
Aft sling length = 1665 mm

Overall dimensions with lifting sling

RIBO 450 15012013.doc

Issue : 8

Date : 15/01/2013

Dimensions and weight +/- 5%
SURVITEC SAS reserves the right to change specification without notice.
For installation, add minimum +10mm for clearance to dimensions of the container.

CAPACITY				
Number of persons: 6			Buoyancy volume: 1458 l / 51.48 cft	
DIMENSIONS				
Length		Width		Buoyancy diameter
Overall	Inside	Overall	Inside	From 0.430 m / 1'5" to 0.487 m / 1'7"
4.50 m / 14'9"	3.52 m / 11'7"	1.90 m / 6'3"	0.93 m / 3'1"	
SAFETY / INFLATION				
. 5 airtight compartments . 5 inflation valves . 5 overpressure valves (Leaffield)				
WEIGHT				
With equipment & batteries		With equipment, engine (40 CV) & fuel		Operational weight with passengers (40 CV)
EC : 246 kg / 542.1 lbs US : 212 kg / 467.2 lbs		EC : 406 kg / 894.8 lbs US : 372 kg / 819.8 lbs		EC : 901 kg / 1985.8 lbs US : 867 kg / 1910.8 lbs
ENGINE				
Shaft length		Engine power		Fuel tanks
long		25 CV 19 kw	40 CV 29.4 kw	SOLAS engines: 2x25 l US engines: 1x6.6 US Gallon
TOWING				
. 2 bow towing rings on hull . 2 towing points on transom		. 1 bow towing V with on load release shackle . 1 aft towing V with snap hook		
HOISTING				
. 2 bow lifting points . 2 aft lifting points on transom . 1 lifting sling				
FABRIC				
. Neoprene orange fabric . Reflective tapes		. Buoyancy . Peripheral rubbing strake		
HULL				
. GRP composite rigid orange hull . Reflective tapes . 1 hull drain				
TRANSOM				
. 1 self bailer		. Engine aluminium mounting plate + wooden plate		

RIBO 450 15012013.doc

Issue : 8

Date : 15/01/2013

Dimensions and weight +/- 5%
SURVITEC SAS reserves the right to change specification without notice.
For installation, add minimum +10mm for clearance to dimensions of the container.

HANDLING			
. Inside lifeline (4.7m)		. Outside lifeline (12.1m)	
SEATING			
. 2 fixed benches		. 1 tilting bench	
EQUIPMENT FIXED TO THE RESCUE BOAT			
. Radar reflector	. Righting lines (2)	. Rescue quoits (2)	. Boarding ladder
. Boat hook	. Positioning light	. Towing line (50m)	
OTHER EQUIPMENT			
. Compass	. Whistle	. Bailer	. Pump
. Sponge (2)	. Sea anchor	. Repair kit	. Manual
. First aid kit	. Floating knife	. Fire extinguisher	. Equipment bag
. Search light *	. Electrical torch	. Telescopic paddles	. Battery box
. Thermal protective aid (2)		. Torch spare bulb & batteries	
* Search light battery is not provided with the boat			
OPTIONS			
. Release hook: SWL \geq 950 kg & \leq 1.5 ton		. Overall cover	
. SOLAS Engines:	Tohatsu M25C3 L -	Maximum towing force: 188 kg Engine weight: 51 kg	
	Tohatsu M40C L -	Maximum towing force: 250 kg Engine weight: 59 kg	
	Yamaha 25NMHOL -	Maximum towing force: 184 kg Engine weight: 50.5 kg	
	Yamaha 40VMHOL -	Maximum towing force: 313 kg Engine weight: 74.5 kg	
. US Engines:	Evinrude E25DTEL -	Maximum towing force: 233 kg Engine weight: 73 kg	
	Evinrude E40DPL -	Maximum towing force: 261 kg Engine weight: 109 kg	
. Propeller pitch:	Evinrude 25 Hp: 3 x 13 x 19	40 Hp: 3 x 13 x 19	
	Tohatsu 25 Hp: 3 x 9.8 x 8	40 Hp: 4 x 11.4 x 7.1	
	Yamaha 25 Hp: 3 x 9 ^{7/8} x 8	40 Hp: 3 x 12 ^{1/4} x 9	

Approvals:

EC (MED) - USCG

RIBO 450 15012013.doc

Issue : 8

Date : 15/01/2013

Dimensions and weight +/- 5%
SURVITEC SAS reserves the right to change specification without notice.
For installation, add minimum +10mm for clearance to dimensions of the container.